

TM 113 B25



Van der Graaf Scandinavia

POWER TRANSMISSION EQUIPMENT

Van der Graaf Scandinavia AB • Box 54, Spinngatan 2 • 260 50 Billesholm
Tfn 042-22 08 02 • Fax 042-22 08 03
www.vandergraaf.se • info@vandergraaf.se

TM 113B25

Type TM 113B25-	Power kW	Beltspeed m/s at 50 Hz Beltpull N										Min L mm	Full load Curr. 400 v - 50 Hz I = ...A	Weight kg L = 310
205 Z	0,37	4,4	4	3,2	2,8	2,5						310	0,8	16
		80	90	110	125	140								
405 Z	0,37	2,2	2	1,6	1,4	1,25	1,1	0,95	0,75	0,6		360	1,35	16
		160	175	220	250	280	320	370	470	585				
405 PL2		0,85	0,7	0,65	0,55	0,5	0,45	0,4	0,34	0,27		360		
		400	485	525	620	680	755	850	1000	1150				
234 Z	0,25	4,4	4	3,2	2,8	2,5						260	0,65	16
		55	60	75	85	95								
434 Z	0,25	2,2	2	1,6	1,4	1,25	1,1	0,95				310	0,7	16
		110	120	150	170	190	215	250						
434 PL2		0,85	0,75	0,7	0,65	0,55	0,5	0,45	0,4	0,34	0,27	310		
		270	305	330	355	420	460	510	575	675	850			
634 Z	0,25	1	0,9	0,8	0,7	0,6	0,5	0,4				360	0,95	16
		240	265	295	340	395	475	595						
634 PL2		0,29	0,25	0,21	0,17							360		
		795	920	1095	1150									
425 Z	0,18	1,6	1,4	1,25	1,1	0,95						275	0,55	16
		105	120	135	155	180								
425 PL2		0,85	0,75	0,7	0,65	0,55	0,5	0,45	0,4	0,34	0,27	275		
		195	220	235	255	300	330	370	415	485	615			
425 PL3		0,2	0,18	0,16	0,13	0,11						310		
		790	880	990	1150	1150								
625 Z	0,18	0,9	0,8	0,7	0,6							310	0,65	16
		190	214	244	285									
625 PL2		0,25	0,21	0,17								310		
		660	790	975										
416 Z	0,12	1,1	0,95									260	0,4	16
		105	120											
416 PL2		0,85	0,75	0,7	0,65	0,55	0,5	0,45	0,4	0,34	0,27	260		
		130	145	160	170	200	220	245	275	325	410			
416 PL3		0,18	0,11	0,07								310		
		585	960	1150										
816 PL2	0,12	0,31	0,22	0,2	0,16	0,13						310	0,65	16
		355	500	550	690	850								
816 PL3		0,1	0,08									360		
		1055	1150											
811 PL2	0,08	0,31	0,26	0,22	0,2	0,16	0,13					260	0,45	16
		235	285	335	370	460	565							
811 PL3		0,1	0,08	0,07	0,06	0,05						310		
		705	880	1005	1150	1150								
807 PL3	0,05	0,06	0,05	0,033								310	0,3	16
		735	880	1150										
807 PL4		0,025	0,023	0,021	0,019	0,016	0,015	0,013	0,012	0,01	0,008	360		
		1150	1150	1150	1150	1150	1150	1150	1150	1150	1150			
805 PL3	0,04	0,1	0,08	0,07	0,06	0,05	0,033					285	0,25	16
		350	440	505	585	705	1065							

Available standard facewidth's

260 - 275 - 310 - 360 - 410 - 460 - 510 - 560 - 610 - 660 - 710 - 760 - 810 - 860 mm

The total weight of a drummotor grows approx. 1,8 kg per 100 mm.

Other beltspeeds and facewidth's upon request.

Available upon request : single phase 220 V - 50 Hz motors.

When an electro-mechanical brake is fitted, the minimum facewidth is increased by 75 mm.

All these drummotors are also available in Stainless Steel - 316

Available torque $\frac{\text{Beltpull N} \times \text{Drum diameter m}}{2}$ (max 65 Nm)

Beltpull max.: 1150 N (I max upon request or nameplate)

TM113B25

Design B

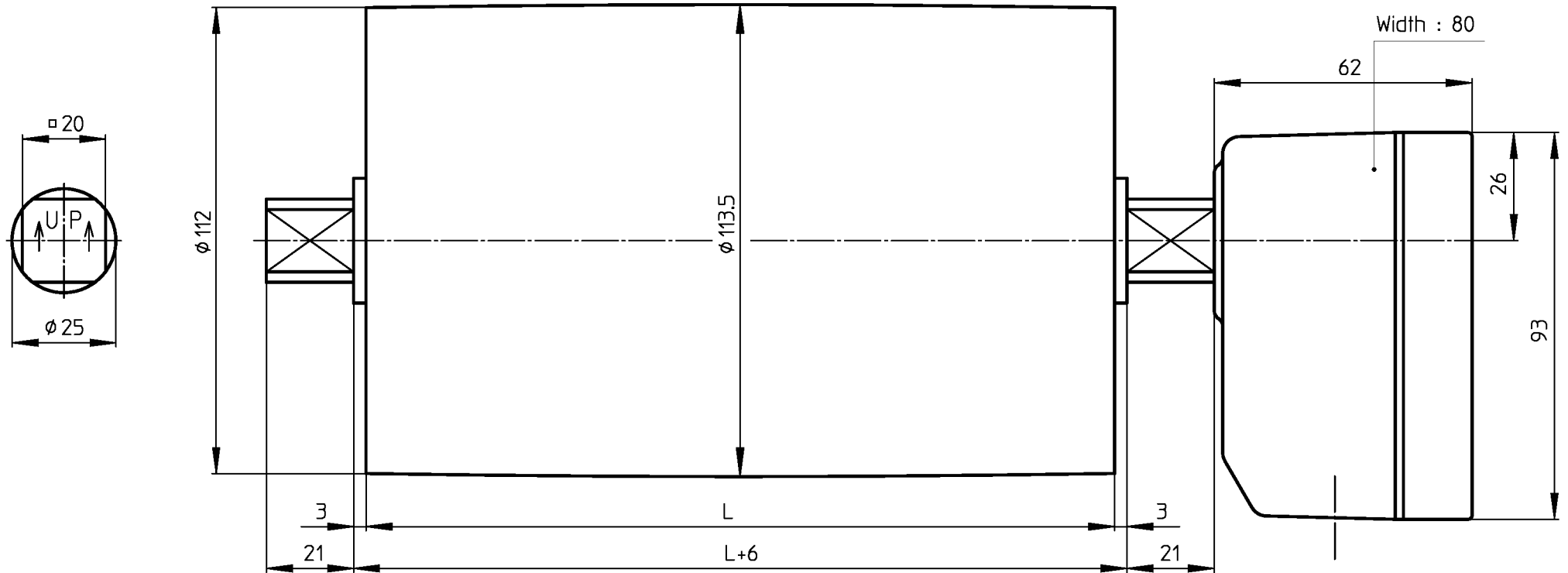

MS_TM113B25_KKKU

22-10-2004



VAN DER GRAAF B.V.

VOLLENHOVE-HOLLAND

Telephone ++31(0)527-241441
Telefax ++31(0)527-241488

KT113B25

Design B

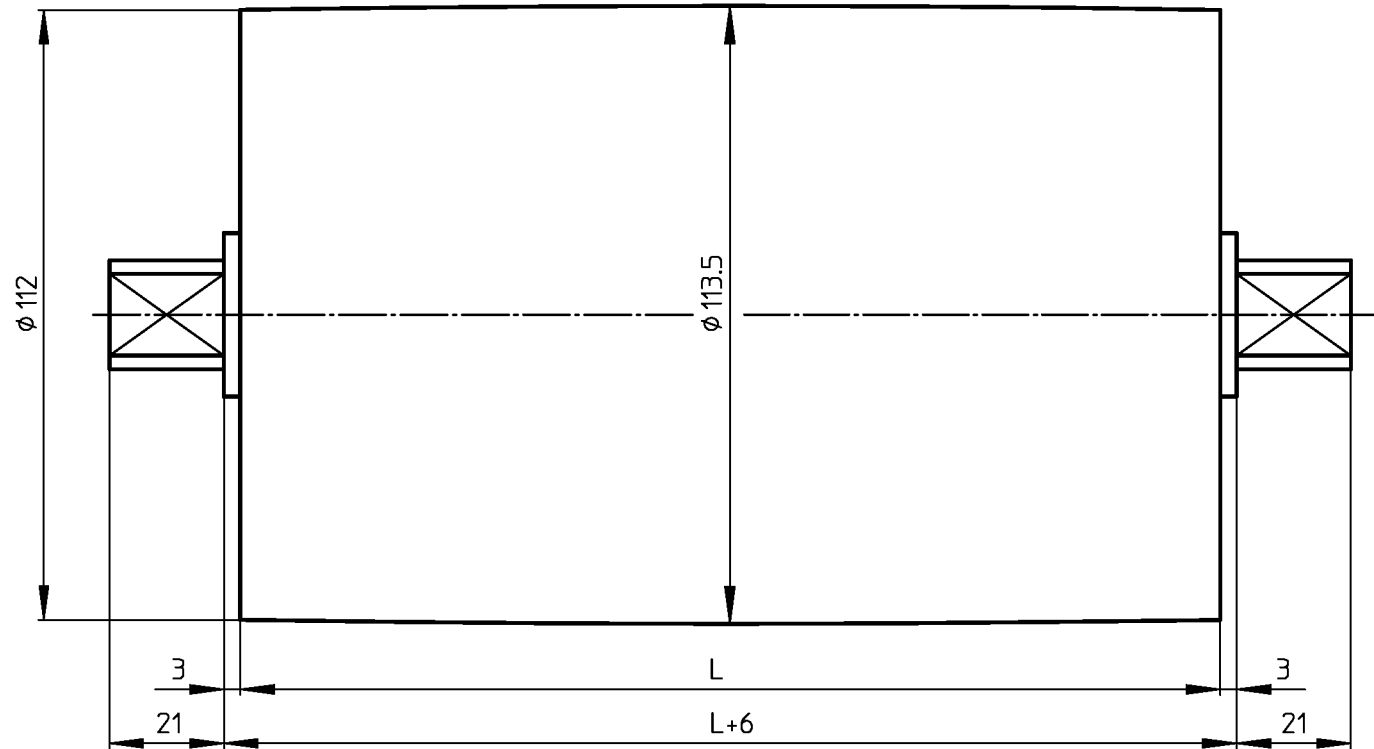
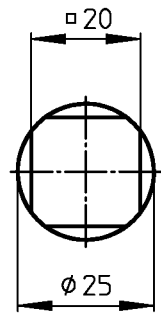

MS_KT113B25

23-06-2000



VAN DER GRAAF B.V.

VOLLENHOVE-HOLLAND

Telephone :+31(0)527-241441
Telefax :+31(0)527-241488

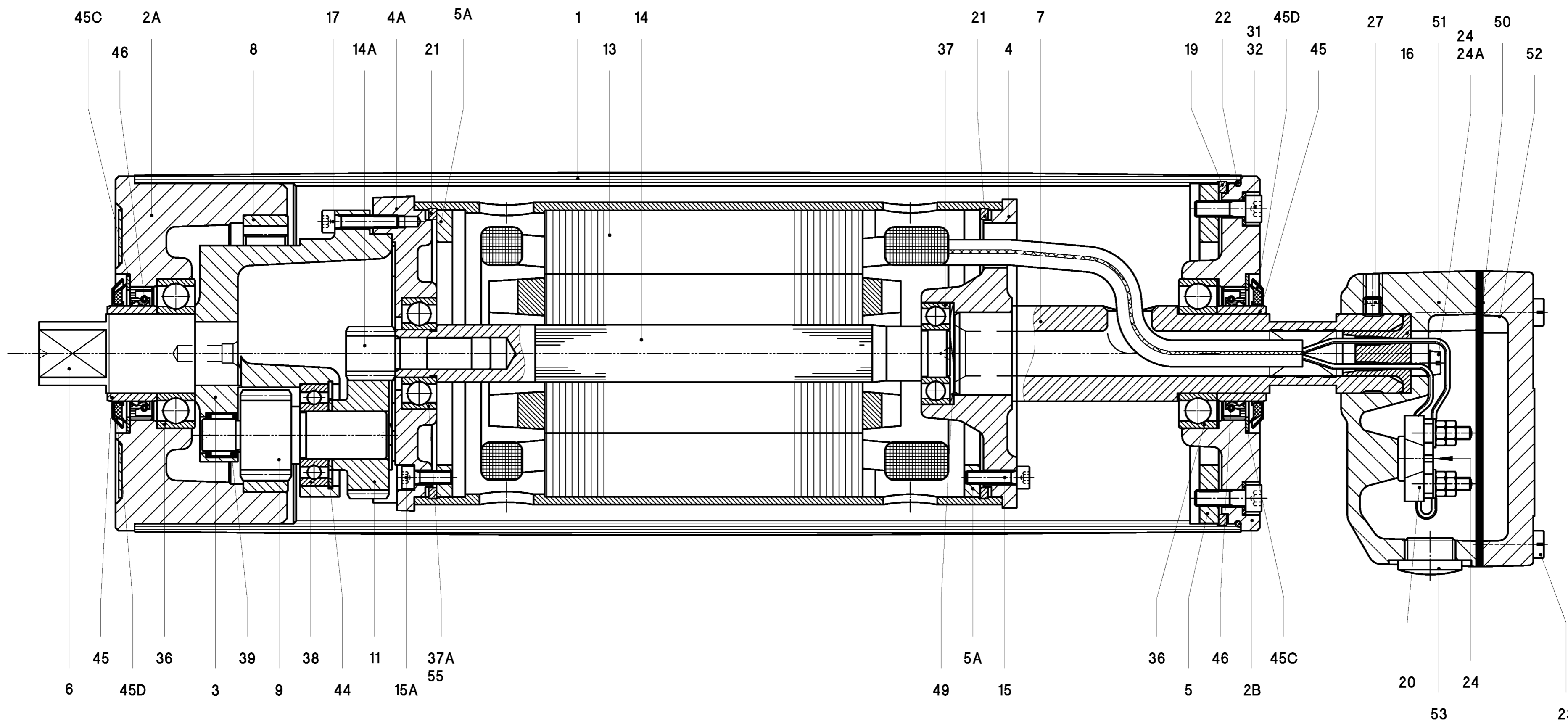

- | | | | | |
|------------------|---------------------|--------------------|------------------|-------------------------------|
| 1 Shell | 8 Internal gear | 19 Springring | 36 Ballbearing | 49 Wave washer |
| 2 A Endflange | 9 Pinion | 20 Terminalboard | 37 Ballbearing | 50 Seal |
| 2 B Endflange | 11 Gear | 21 Springring | 37 A Ballbearing | 51 Junctionbox |
| 3 Gearinghousing | 13 Stator | 22 O-ring | 38 Ballbearing | 52 Junctionbox cover |
| 4 Motorflange | 14 Rotor | 23 Cyl. Head screw | 39 Needlebearing | 53 Blindstop |
| 4 A Motorflange | 14 A Insert pinion | 24 Cyl. Head screw | 44 Circlip | 55 Ballbearing incl. backstop |
| 5 Mountingring | 15 Int. Hex screw | 24 A Star washer | 45 Bearing race | 57 Dataplate |
| 5 A Mountingring | 15 A Int. Hex screw | 27 Setscrew | 45 C Shim plated | |
| 6 Shaftend | 16 Cable passage | 31 Int. Hex screw | 45 D Gammaring | |
| 7 Hollow Shaft | 17 Int. Hex screw | 32 Bonded seal | 46 Oilseal | |

		~ onbewerkt ▽ ruw bewerkt ▽▽ glad bewerkt ▽▽▽ fijn bewerkt ▽▽▽▽ geslepen ▽▽▽▽▽ gehoord ▽▽▽▽▽▽ getapt		Amerikaanse Projectie
		MAATTOLERANTIES VOLGENS NEN 2365		
		Schaal: 1 : 1 Datum		
		Getekend: G.R. 18-10-04		
		Gec.: Gezien:		
Wijz.	Omschrijving	Dat.	Par. B.V. BS:	
Materiaal:		Benaming: DRUMMOTOR		
		COAXIAAL		
VAN DER GRAAF B.V. VOLLENHOVE (+31(0)527-241441) HOLLAND		Formaat A2	Tekeningnr. TM113B25_00_Z_KKKU	
<small>Deze tekening is eigendom van VAN DER GRAAF B.V. Iedere vervreemding, vermenigvuldiging en openbaarmaking aan derden is strafbaar.</small>				

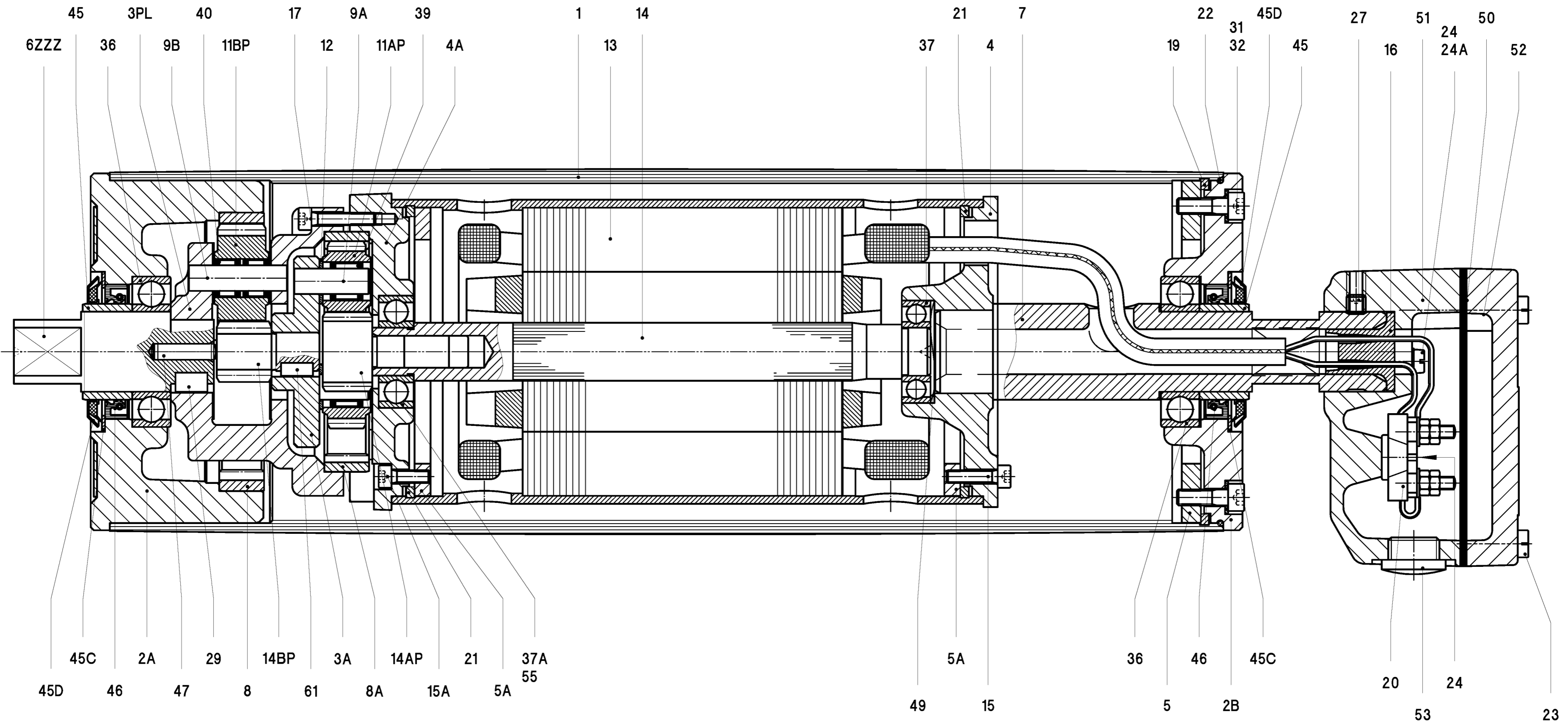

- | | | | | |
|------------------------|----------------------|---------------------|-------------------|-------------------------------|
| 1 Shell | 8 Internal gear | 15 Int. Hex screw | 27 Setscrew | 45 D Gammaring |
| 2 A Endflange | 8 A Internal gear | 15 A Int. Hex screw | 29 Key | 46 Oilseal |
| 2 B Endflange | 9 A Cylindrical pin | 16 Cable passage | 31 Int. Hex screw | 49 Wave washer |
| 3 A Planetary carrier | 9 B Cylindrical pin | 17 Int. Hex screw | 32 Bonded seal | 50 Seal |
| 3 PL Planetary housing | 11 AP Planetary gear | 19 Springring | 36 Ballbearing | 51 Junctionbox |
| 4 Motorflange | 11 BP Planetary gear | 20 Terminalboard | 37 Ballbearing | 52 Junctionbox cover |
| 4 A Motorflange | 12 Shim | 21 Springring | 37 A Ballbearing | 53 Blindstop |
| 5 Mountingring | 13 Stator | 22 O-ring | 39 Needlebearing | 55 Ballbearing incl. backstop |
| 5 A Mountingring | 14 Rotor | 23 Cyl. Head screw | 40 Needlebearing | 57 Dataplate |
| 6 Shaftend | 14 AP Insert pinion | 24 Cyl. Head screw | 45 Bearing race | |
| 7 Hollow Shaft | 14 BP Sunwheel | 24 A Star washer | 45 C Shim plated | |

~ onbewerkt ▽ ruw bewerkt ▽▽ glad bewerkt ▽▽▽ fijn bewerkt ▽▽▽▽ geslepen ▽▽▽▽▽ gehoond ▽▽▽▽▽▽ gelapt		Amerikaanse Projectie
Schaal: 1 : 1		Datum
Getekend: G.R.		18-10-04
Gec.: _____		Gezien: _____
Wijz. Omschrijving	Dat. Par.	B.V. BS:
Materiaal:		Benaming: DRUMMOTOR
		PLANETAIR
VAN DER GRAAF B.V. VOLLENHOVE (+31(0)527-241441) HOLLAND		Formaat Tekeningsnr. A2 TM113B25_00_PL2_KKKU
<small>Deze tekening is eigendom van VAN DER GRAAF B.V. Iedere vervreemding, vernoemingsrecht en openbaarmaking aan derden is strafbaar.</small>		

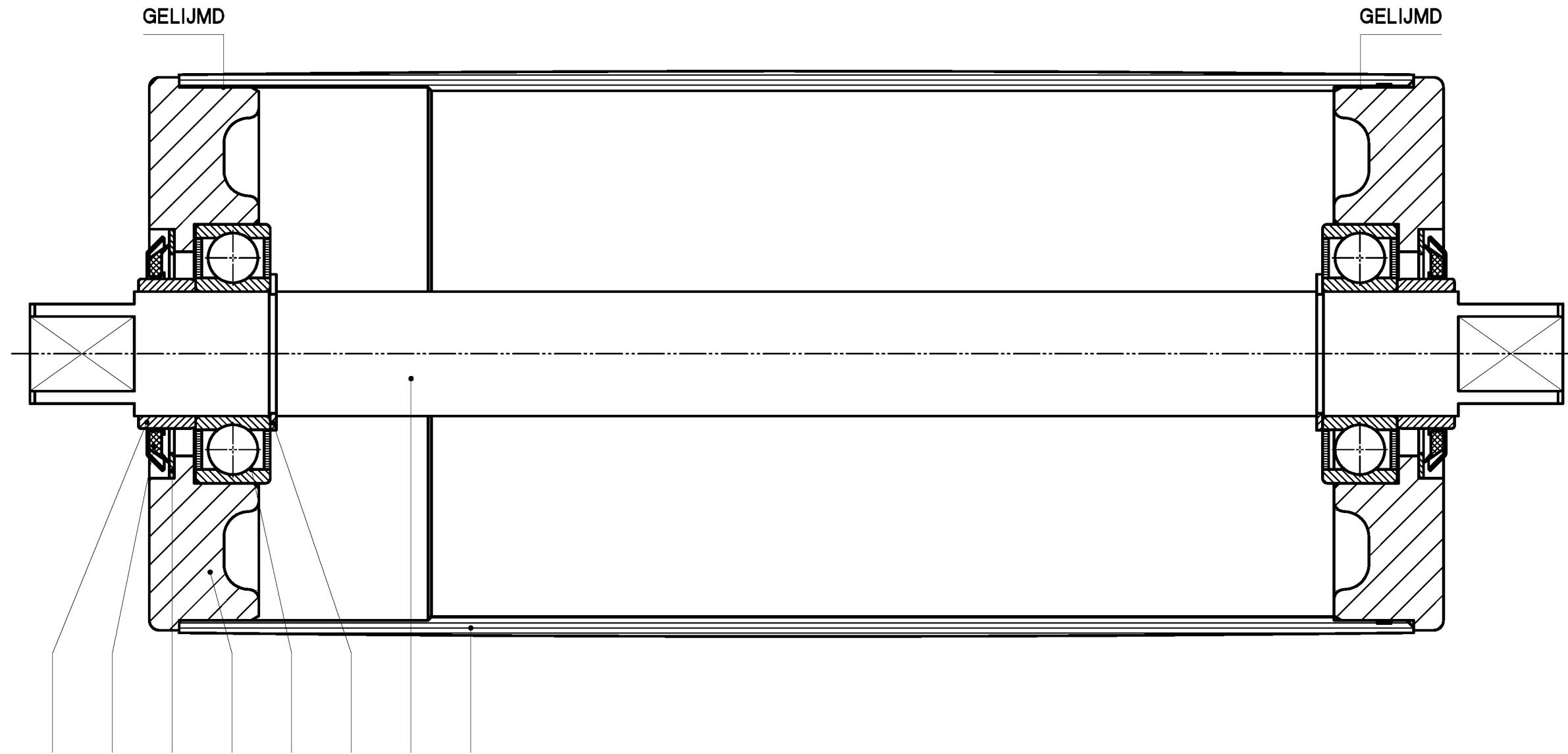

45 45D 45C 2 4 42 3 1

- 1 Shell
- 2 A Endflange
- 3 Shaft
- 4 Ballbearing
- 42 Circlip
- 45 Bush
- 45 C Shim plated
- 45 D Gammaring

					~ onbewerkt ▽ ruw bewerkt ▽▽ glad bewerkt ▽▽▽ fijn bewerkt ▽▽▽ geslepen ▽▽▽ gehoond ▽▽▽ gelapt	Amerikaanse Projectie MAATTOLERANTIES VOLGENS NEN 2365
					Schaal: 1 : 1	Datum
					Getekend: S.Z.	15-04-98
					Gec.:	Gezien: 26-11-02
Wijz.	Omschrijving	Dat.	Par.	B.V.	BS:	
Materiaal:		Benaming: KEERTROMMEL				
VAN DER GRAAF B.V. VOLLENHOVE (+31(0)527-241441) HOLLAND				Formaat	Tekeningnr.	
				A3	KT113B25_00	
Deze tekening is eigendom van VAN DER GRAAF B.V. Iedere verveemding, vermenigvuldiging en openbaarmaking aan derden is strafbaar.						