

TM 138.25



Van der Graaf Scandinavia

POWER TRANSMISSION EQUIPMENT

Van der Graaf Scandinavia AB • Box 54, Spinngatan 2 • 260 50 Billesholm
Tfn 042-22 08 02 • Fax 042-22 08 03
www.vandergraaf.se • info@vandergraaf.se

TM 138.25

Type TM 138.25	Power kW	Beltspeed m/s at 50 Hz Beltpull N					Min. L mm Design		Full load Curr. 400 V - 50 Hz I = ...A	Weight kg L=350
							A	B		
210 Z	0,75	2,8	2,2	1,8						
		255	325	395			300	325	1,7	22
410 Z	0,75	1,4	1,1	0,9	0,55	0,55				
		510	650	790	1295		300	325	1,9	22
410 PL2		0,32	0,26	0,22	0,17					
		2155	2655	3135	3800		350	375		
275 Z	0,55	2,8	2,2	1,8						
		185	240	290			275	300	1,1	20
475 Z	0,55	1,4	1,1	0,9	0,7	0,55	0,45			
		375	475	580	745	950	1160		275	300
475 PL2		0,32	0,26	0,22	0,17					
		1580	1945	2300	2975		325	350	1,3	20
205 Z	0,37	2,8	2,2	1,8						
		125	160	195			250	275	0,9	19
405 Z	0,37	1,4	1,1	0,9	0,7	0,55	0,45	0,35		
		250	320	390	500	640	780	1005	275	300
405 PL2		0,22	0,17							
		1545	2000				325	350	1	19
405 PL3		0,05	0,039	0,033	0,026					
		3800	3800	3800	3800		375	400		
605 Z	0,37	0,27								
		1300					275	300	1,1	20
605 PL2		0,15	0,12							
		2270	2835				325	350		
434 Z	0,25	1,4	1,1	0,9	0,7	0,55	0,45	0,35		
		170	215	265	340	430	530	680	250	275
834 Z	0,25	0,27	0,22	0,17						
		880	1080	1395			275	300	1	20
834 PL2		0,13	0,11	0,09						
		1770	2090	2555			325	350		
834 PL3		0,025	0,019	0,016	0,013					
		3800	3800	3800	3800		375	400		
825 Z	0,18	0,27	0,22	0,17						
		635	775	1005			275	300	0,8	19
818 Z	0,13	0,27	0,22	0,17						
		455	560	725			250	275	0,6	18
1218 Z	0,13	0,13	0,11							
		950	1125				300	325	0,9	22
1218 PL2		0,09	0,08	0,05						
		1330	1495	2390			350	375		
1218 PL3		0,016	0,013	0,011	0,009					
		3800	3800	3800	3800		400	450		
1213 Z	0,1	0,13	0,11							
		730	865				275	300	0,6	20

Available standard facewidth's

250 - 275 - 300 - 325 - 350 - 375 - 400 - 450 - 500 - 550 - 600 - 650
700 - 750 - 800 - 850 - 900 - 950 - 1000 mm

The total weight of a drummotor grows approx. 2,0 kg per 100 mm.

Two speed drummotors upon request

Other beltspeeds and facewidth's upon request.

Available upon request : single phase 220 V - 50 Hz motors.

When an electro-mechanical brake is fitted, the minimum facewidth is increased by 100 mm

All these drummotors are also available in Stainless Steel - 316

Available torque
$$\frac{\text{Beltpull N} \times \text{Drumdi}}{2}$$
 (Max. 260 Nm)

Beltpull max.: 3800 N (I max upon request or nameplate)

TM138A25

Design A

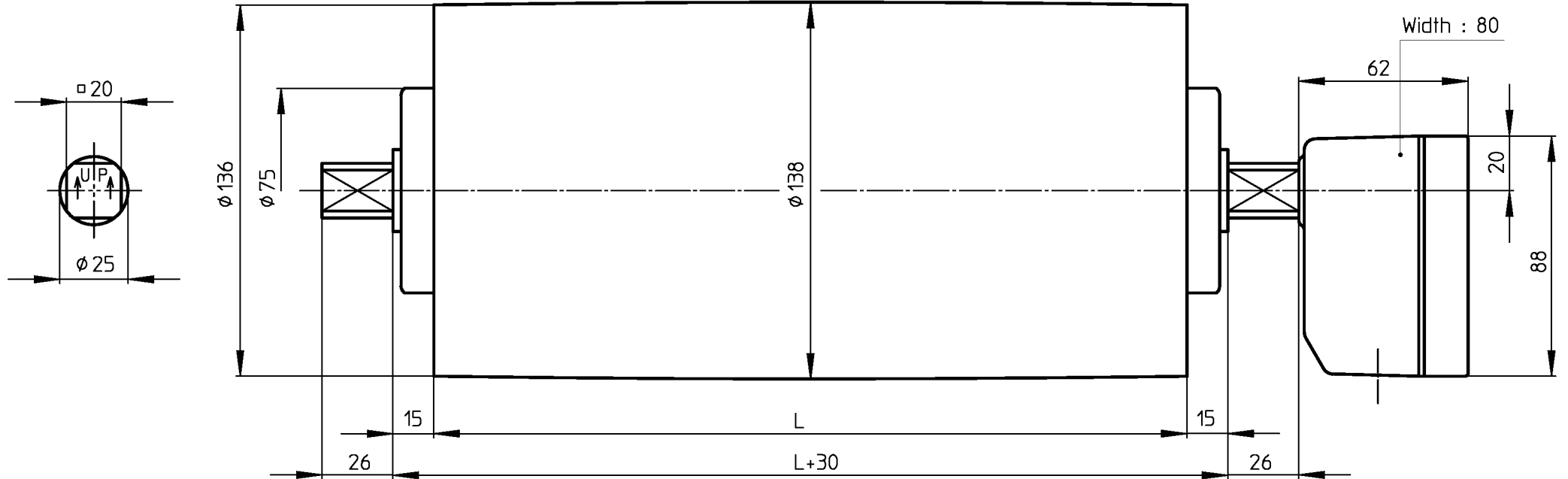

MS_TM138A25_KKGG

16-06-2004



VAN DER GRAAF B.V.

VOLLENHOVE-HOLLAND

Telephone :+31(0)527-241441
Telefax :+31(0)527-241488

KT138A25

Design A

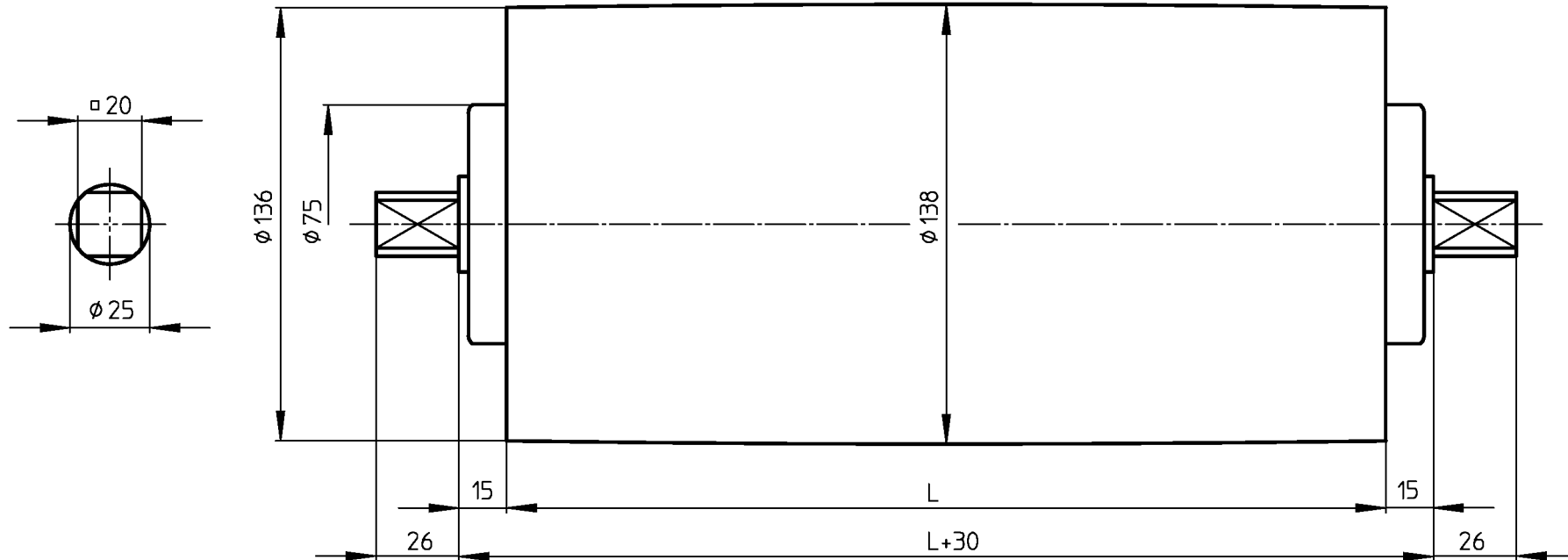

MS_KT138A25

23-06-2000



VAN DER GRAAF B.V.

VOLLENHOVE-HOLLAND

Telephone :+31(0)527-241441
Telefax :+31(0)527-241488

ASBLOK/BRACKET/LAGERBOCK AB25

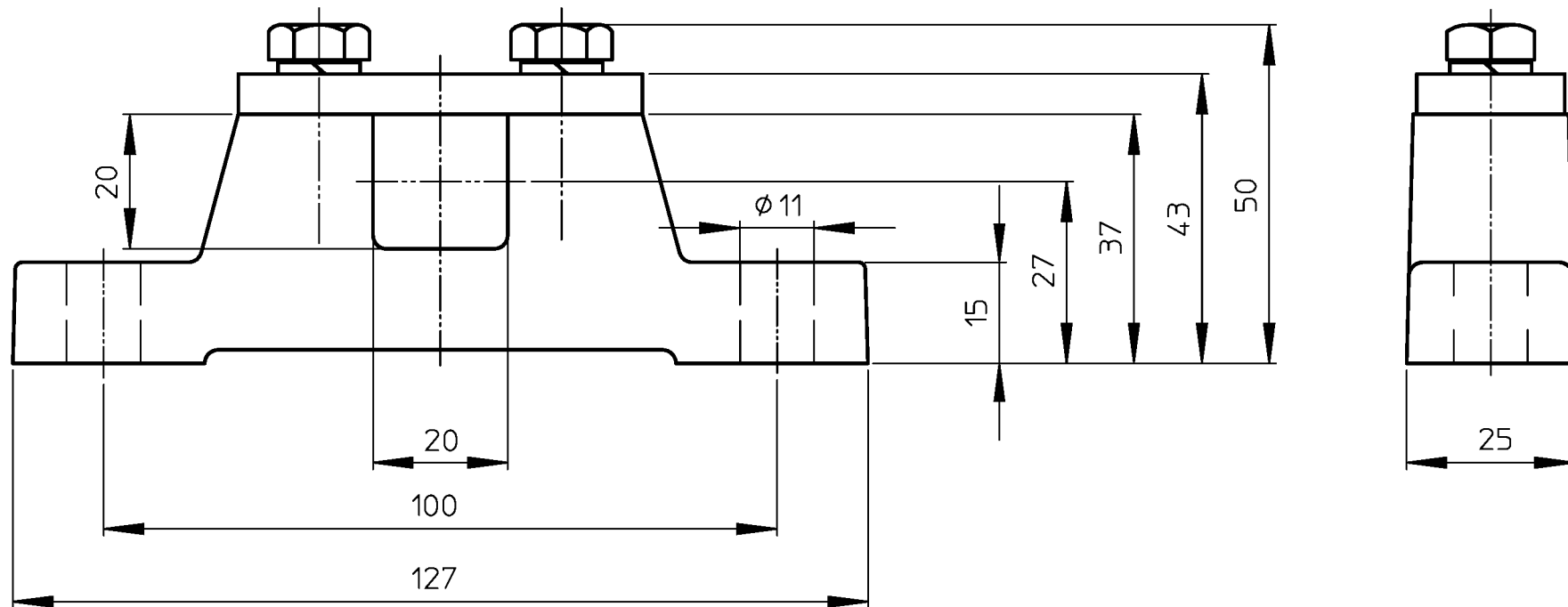

MS_AB25

22-07-99



VAN DER GRAAF B.V.

VOLLENHOVE-HOLLAND

Telephone :+31(0)527-241441
Telefax :+31(0)527-241488

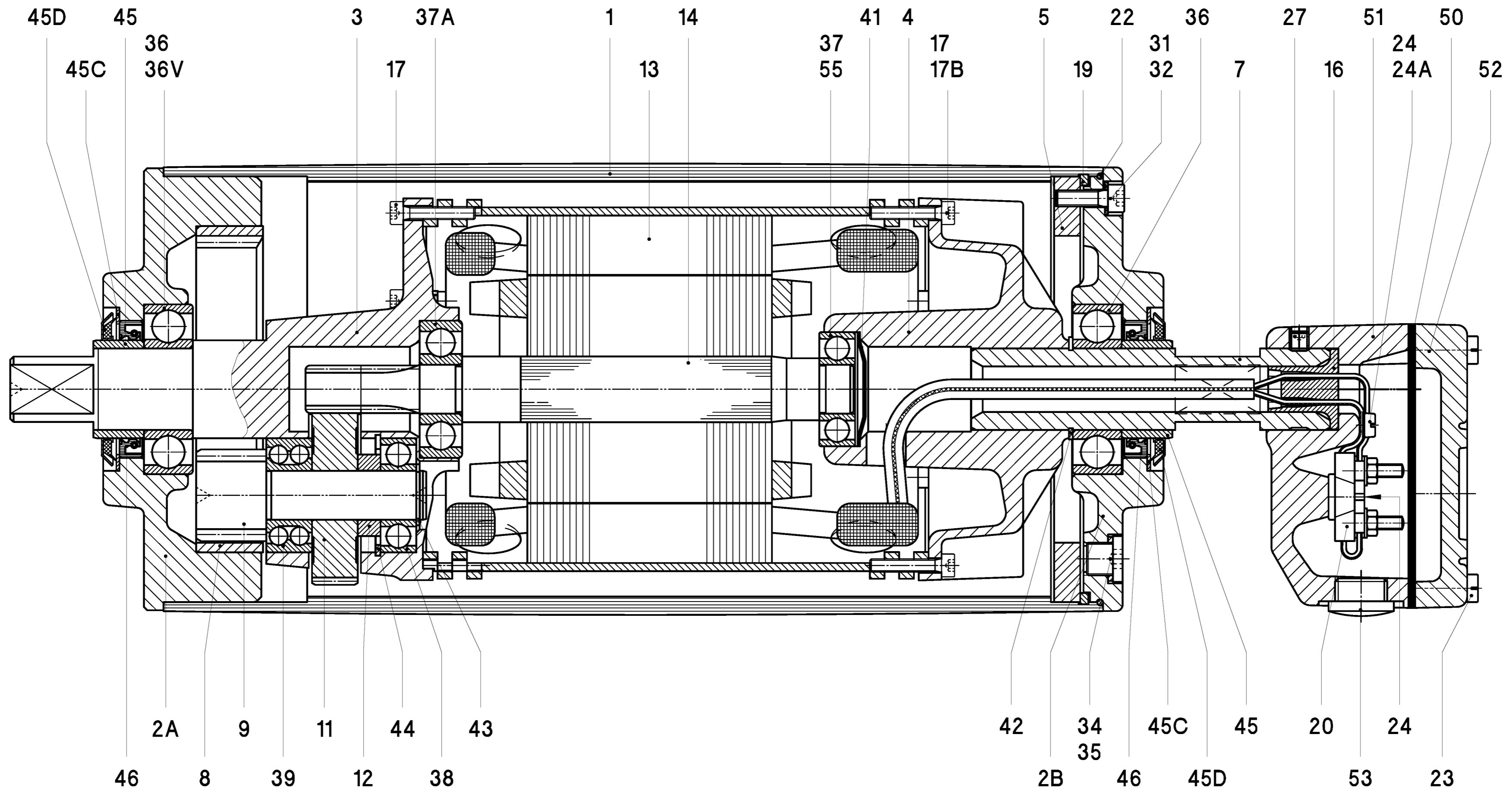

- | | | | | |
|------------------|--------------------|-------------------|------------------|-------------------------------|
| 1 Shell | 12 Distance ring | 24 A Star washer | 39 Ballbearing | 52 Junctionbox cover |
| 2 A Endflange | 13 Stator | 27 Setscrew | 41 Locking disc | 53 Blindstop |
| 2 B Endflange | 14 Rotor | 31 Int. Hex screw | 43 Circlip | 55 Ballbearing incl. backstop |
| 3 Gearinghousing | 16 Cable passage | 32 Bonded seal | 44 Circlip | 57 Dataplate |
| 4 Motorflange | 17 Int. Hex screw | 34 Fillerplug | 45 Bearing race | |
| 5 Mountingring | 19 Springring | 35 Washer | 45 C Shim plated | |
| 7 Hollow Shaft | 20 Terminalboard | 36 Ballbearing | 45 D Gammaring | |
| 8 Internal gear | 22 O-ring | 37 Ballbearing | 46 Oilseal | |
| 9 Pinion | 23 Cyl. Head screw | 37 A Ballbearing | 50 Seal | |
| 11 Gear | 24 Cyl. Head screw | 38 Ballbearing | 51 Junctionbox | |

		~ onbewerkt ▽ ruw bewerkt ▽▽ glad bewerkt ▽▽▽ fijn bewerkt ▽▽▽▽ geslepen ▽▽▽▽▽ gehoond ▽▽▽▽▽▽ getapt		Amerikaanse Projectie	
		Schaal: 1 : 1		Datum	
		Getekend: S.Z.		02-07-01	
		Gec.:		Gezien: J.K. 14-10-04	
Wijz. Omschrijving		Dat. Par.		B.V. BS:	
Materiaal:		Benaming: DRUMMOTOR			
VAN DER GRAAF B.V. VOLLENHOVE (+31(0)527-241441) HOLLAND		Formaat A2	Tekeningsnr. TM138A25_00_Z		
<small>Deze tekening is eigendom van VAN DER GRAAF B.V. Iedere vervreemding, vernieuwing en openbaarmaking aan derden is strafbaar.</small>					

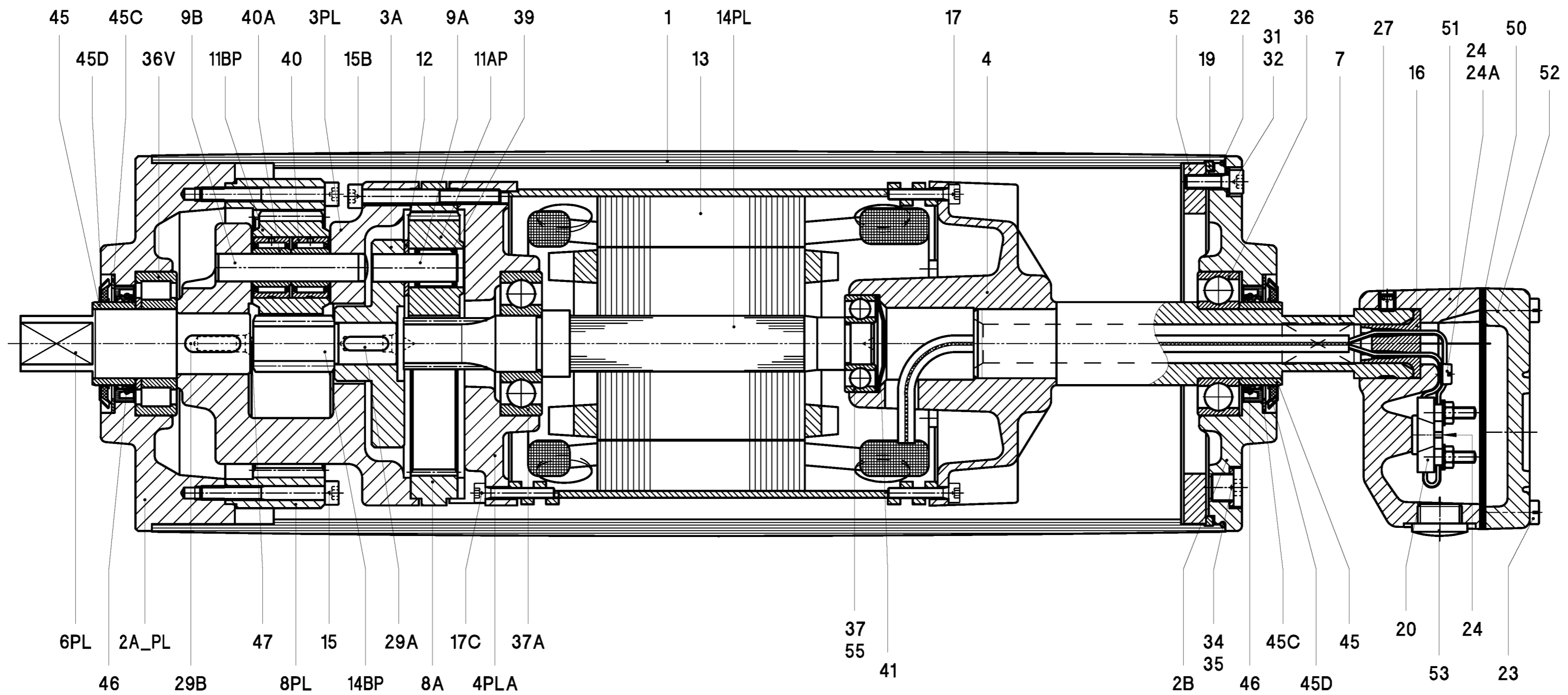

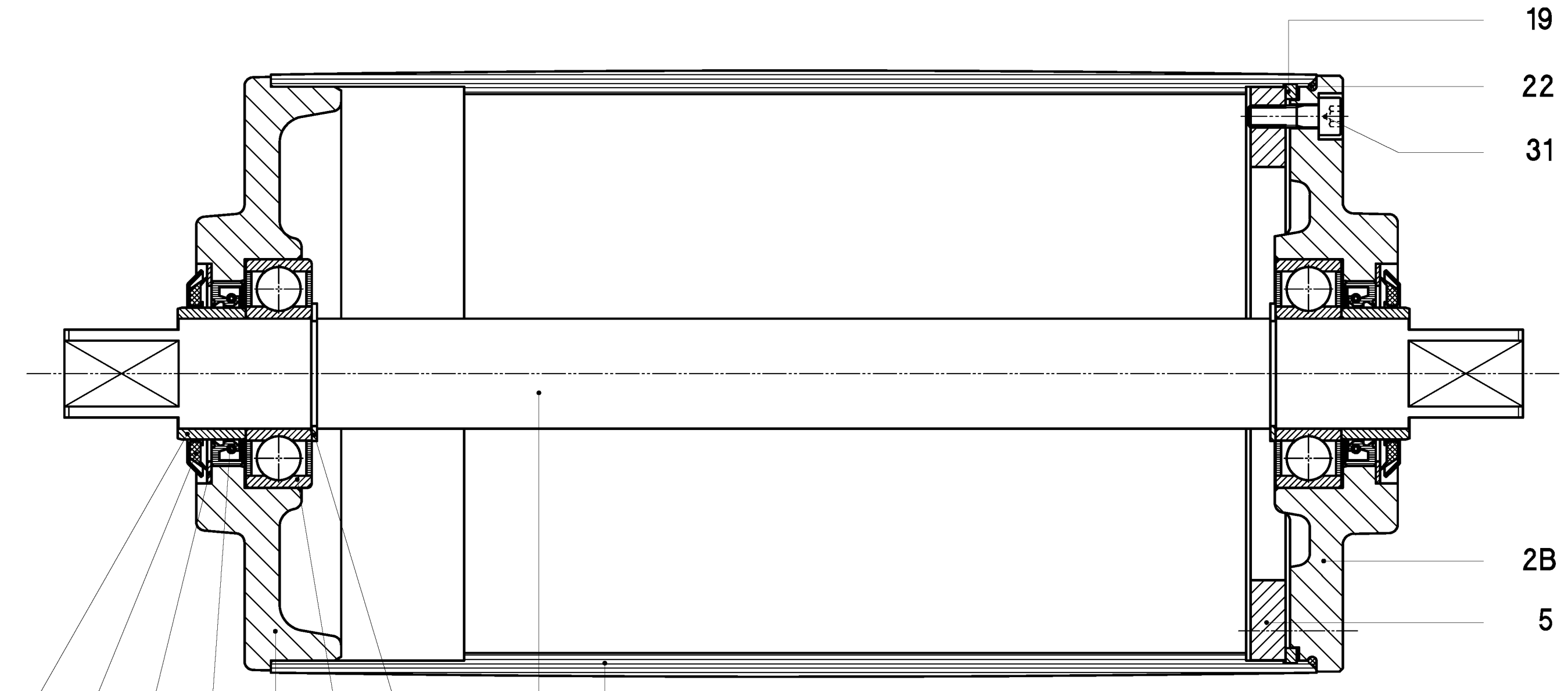

1 Shell	9 A Cylindrical pin	19 Springring	34 Fillerplug	45 D Gammaring
2 A-PL Endflange	9 B Cylindrical pin	20 Terminalboard	35 Washer	46 Oilseal
2 B Endflange	11 AP Planetary gear	22 O-ring	36 Ballbearing	50 Seal
3 A Planetary carrier	11 BP Planetary gear	23 Cyl. Head screw	36 V Cylinder bearing	51 Junctionbox
3 PL Planetary housing	12 Shim	24 Cyl. Head screw	37 Ballbearing	52 Junctionbox cover
4 Motorflange	13 Stator	24 A Star washer	37 A Ballbearing	53 Blindstop
4 PLA Motorflange	14 PL Rotor	27 Setscrew	39 Needlebearing	55 Ballbearing incl. backstop
5 Mountingring	14 BP Sunwheel	28 Setscrew	40 Needlebearing	57 Dataplate
6 PL Shaftend	15 Int. Hex screw	29 A Key	40 A Innerring	
7 Hollow Shaft	16 Cable passage	29 B Key	41 Locking disc	
8 A Internal gear	17 Int. Hex screw	31 Int. Hex screw	45 Bearing race	
8 PL Internal gear	17 C Int. Hex screw	32 Bonded seal	45 C Shim plated	

		~ onbewerkt v ruw bewerkt vv glad bewerkt vvv fijn bewerkt vvvv geslepen vvvv geborend vvvv gelapt		Amerikaanse Projectie	
		Schaal: 1 : 1		Datum	
		Getekend: S.Z.		13-07-01	
		Gec.:		Gezien: J.K. 18-10-04	
Wijz.	Omschrijving	Dat.	Par.	B.V.	BS:
Materiaal:		Benaming: DRUMMOTOR			
		PLANETAIR			
VAN DER GRAAF B.V. VOLLENHOVE (+31(0)527-241441) HOLLAND		Formaat: A1	Tekeningnr.: TM138A25_00_PL2		
<small>Deze tekening is eigendom van VAN DER GRAAF B.V. iedere verveem- ding, verspreiding en openbaarmaking aan derden is strafbaar.</small>					

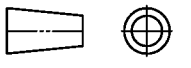

45 45D 45C 46 2A 4 42 3 1

- | | | | |
|-----|----------------|------|----------------|
| 1 | Shell | 22 | O-ring |
| 2 A | Endflange | 31 | Int. Hex screw |
| 2 B | Endflange | 42 | Circlip |
| 3 | Gearinghousing | 45 | Bearing race |
| 4 | Ballbearing | 45 C | Shim plated |
| 5 | Mountingring | 45 D | Gammaring |
| 19 | Springring | 46 | Oilseal |

		~ onbewerkt ▽ ruw bewerkt ▽▽ glad bewerkt ▽▽▽ fijn bewerkt ▽▽▽▽ gestepen ▽▽▽▽▽ gehoond ▽▽▽▽▽▽ gelapt		Amerikaanse Projectie  MAATTOLERANTIES VOLGENS NEN 2365	
		Schaal: 1 : 1		Datum	
		Getekend: S.Z.		21-04-98	
		Gec.:		Gezien: 22-11-02	
Wijz. Omschrijving		Dat. Par.		B.V. BS:	
Materiaal:		Benaming: KEERTROMMEL			
 VAN DER GRAAF B.V. VOLLENHOVE (+31(0)527-241441) HOLLAND		Formaat A3 Tekeningsnr. KT138A25_00		Deze tekening is eigendom van VAN DER GRAAF B.V. Iedere vervreemding, vermenigvuldiging en openbaarmaking aan derden is strafbaar.	